

The Impact of Earning Management On Market Performance: The Empirical Study on Dividend and Working Capital

Muljanto Siladjaja

Faculty Of Economic Department Management

Perbanas Institute

Jl. Perbanas Karet Kuningan, Setiabudi, Jakarta 12940, Indonesia

Abstract. *Purpose* - This research is to develop the integrated modeling for illustrating the influence of accruals against on the market value of firm performance through the corporate event policy, both the policy of dividend payout and working capital, so this causal relationship involves the quality of accruals. On the side, this research tests the capability skill of investors to detect the earnings management by the period of publication, when the issue was released out formally and informally. This research proves the empirical testing, earnings management that are commonly used to sending out the message or signaling to the market about firm performance, this fundamental aim is to matching the different perception. *Design / Methodology Approach* - This research used the statistical models by developing the ANOVA analysis, the path model analysis and multivariate regression, where our explanatory causal research have two stages of the data analysis. Primarily, we used the testing the influence of discretionary accruals by path analysis and multivariate regression. By getting rid of the available error or bias, the object of this research was all the listed company period 2001-2016, where it has the purposive sampling. This research used the Amos and SPSS at the significant level at 5%. *Finding* - The critical finding that all public firm have systematic method for earnings management, we distinguished the discretionary accruals, when it had the high and low accruals, it is measured by the percentage of the total accruals. The discretionary accruals have the negative influence on the market value significantly, both indirect and direct impact. The indirect could be done by the positive relationship with a dividend and a negative relationship with working capital. The other finding is the impact on the quality of accruals, when estimating the risk of the firm and the usefulness of financial reporting. This research try to prove the dividend policy, based on the earnings management, and working capital had been the sensitive indicator for investors. *Research Limitation / Implication* - This research based on the fundamental analysis, then developed into accruals testing with Kothari Model. When we used the financial indicators, it so brings so many limitations, like the lag period and time horizon. By ignoring the error in time horizon accruals in the long run, this research testing between the accruals and corporate events policy. *Practical Implication* - This research has pointed out the financial reporting still be the most valuable document and the high usefulness in taking investment decision. The investors have capability to detect the earnings management and capable to of make a judgment, when the high accruals could be found. When a firm released out the financial reporting, it is just like a game theory. When financial reporting have the high accruals, so this management used the conservative method in reducing out the risk, as we commonly known as the quality of accruals. *Originality / value*- The research have developed out the mutual relationship with corporate earnings management policy and market value by proposing the concept of market value of accruals, high payout dividend yield and quality of accruals. By re-shaping the new paradigms of dividend payout, and increasing capability skills of investors, we develop the matrix of game theory models in illustrating investor and management behavior; include the pattering of flexibility of accounting method.

Keywords. Discretionary Accruals, Working Capital, Dividend Pay Out, Quality of Accruals, Cost of Capital.

Corresponding Author. Muljantosiladjaja@gmail.com

How to Cite This Article. Muljanto Siladjaja. (2019). The Impact of Earning Management On Market Performance: The Empirical Study on Dividend and Working Capital. *Jurnal ASET (Akuntansi Riset)*, 11 (2), 199-214.

History of Article. Received : Agustus 2019, **Revision:** Desember 2019, **Published:** Desember 2019

Online ISSN: 2541-0342. Print ISSN: 2086-2563. DOI : 10.17509/jaset.v11i2.19248

Copyright©2019. Jurnal ASET (Akuntansi Riset) Program Studi Akuntansi FPEB UPI

BACKGROUND

In the development of accounting research literature, started with a study of the influence of corporate profits on stock price movements in the 60-70's. The research of Ball and Brown (1968), which became a

monumental study and dominate the theory and research of market based accounting and finance since 1968, tested the correlation between the sign of unexpected earnings to the average of abnormal rates of return. In the same year, Beaver (1968) conducted a study

on the correlation of profit and trading volume, by proving the effect of financial statements publication to the return investors' level, the company's profit has informativity level for investment decisions. The financial statements have useful decision level, because the accounting report contains information that can affect the stock market's price.

The development of financial and accounting research is related the emergence and the development of Positive Accounting Theory (Watts and Zimmerman, 1986), which is dominant in current accounting research. It is supported by Milton Friedman (in Kothari *et al*, 2005) who adopted the positive economics science to the model of accounting research. Despite of using normative theory, he used the positive theory that use the arguments explaining how the stock exchange works in reality. The various studies of accounting research have found earnings management behavior, in which the accruals can be used to predict company's profits, included the accruals accounting by Sloan (1996) and the study of earnings management by Healy (1985), Jones (1991) and Sweeney (1994) and Dechow *et al*, (1996).

Regarding the case of earnings management in Indonesia, Sylvia and Utama (2005) assumed that a management has an opportunist characteristic in running the company for its personal interests which influenced by the ownership majority and company's size. This behavior applied *income increasing* or *decreasing discretionary income accruals*. Leuz *et al*. (2003) showed that Indonesia is classified in countries' clusters that have weak protection for investors, in which the earnings management occurred. This statement is similar to the study of Myring (2006) that categorized it into "the emerging markets".

By adopting IFRS, with the new principle based standard, the asset assessment is based on the fair value. The objective of fair value usage is to improve the transparency and quality of financial report. In Indonesia, the IFRS adoption also attracts attention and becomes an interesting phenomenon. The revision then made to

PSAK when adopting IFRS, Prima *et. al*. (2012) showed that the IFRS adoption has no significant effect to the earnings management. The result analysis showed that statistically there is no significant difference between earning management level, before before and after adopting IFRS. This finding does not meet the research expectations that there is a declining in earning management after adopting IFRS.

First: The Implications of Dividend Payout Policy and Earning Management

This study investigated the correlation between dividend payout policy with earnings management behaviors, in which the dividend amount is able to affect the stock market value positively and significantly. The dividend payout policy is used as "signaling" to the company's performance, which is able to influence the investor's perception. Alwi (2009) studied that the dividend policy is used to reduce the agency conflict between the majority and minority stakeholders.

Kato (2002) wrote about the dividend policy related to earning management through "accruals and deferral" item based on Japanese government's banking regulations. The implications of the dividend payments reached 40% of net income until August 1992. The research of dividend payout policy research with earning management was firstly conducted by Kasanen (1996), assumed there are high demand dividend and "*dividend smoothing*". The dividend's role is as "*an active signal*" for the investors regarding of cash flow availability and not as a signal for the next company's performance. It is related with the earning management activity, whereas the companies have various motives in conducting the dividend payout policy, Lilian *et. al*. (2012). In her research assumed that mentioned that the company tends to conduct the dividend payout policy, to get high repayment. It aims to give a good signal and do the camouflage against the minority stakeholders rights violations.

Second: Working Capital Policy and Earning Management

The effect of working capital policy, which is a very sensitive indicator, is very important for investor's decision (Kerstein and Rai 2007). In fact, the investor's attentions focus on the working capital components as an earning management item,

the effects of working capital changing becomes a major concern compared to the increase of company's earning. The managers also prefer to reporting a small increase of earning rather than losses, that uses discretionally accruals (Dechow and Dichev, 2002). The Interaction of working capital and dividend is explained by the figures below:

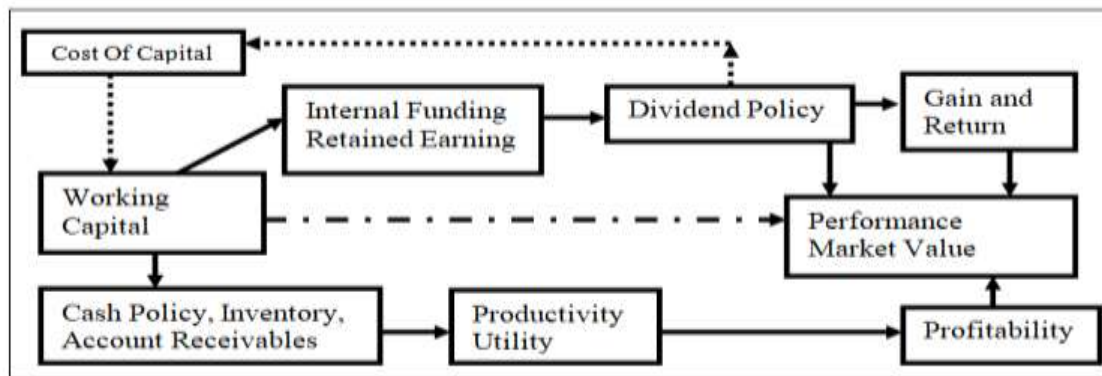

Note: Myers (1984); Gombola and Ketz (1983), Soenen (1993) Titman (1988); Baker (2002), Deshmukh (2005), Lazaridis (2006), Kesanen (1996), Mahdiye (2013), Bandi (2012), Tong and Greene (2005), Kerstein and Rai (2007) Scott (2012), Megginson (1997) and Yoon, et al (1995)

Figure 1 Scope of Working Capital and Dividends and Stock Market Value.

THEORITICAL FRAMEWORK

Problem Identification

Dechow and Dichev (2002) introduced the concept of accruals quality to measure the company risk. It is similar to Watts and Zimmerman (1978), Roychowdhury (2006) and Cohen and Zarowin (2010) that accruals-based earnings management. The Management's capability to conduct earning management was assured having "mis-leading" financial report indicators. The disability and failures of investors to anticipate and detect the aggressive accruals, is also examined by Bradshaw *et al.* (1999, p. 2 in Kothari *et al.*, 2005) he said "investors do not fully anticipate the negative implications of unusually high accruals".

Based on the occurrence of financial "mis-leading" to the investment decisions and investor's detection ability of earnings management, this research dissertation is formulated as follows: (1) How does the earnings management, through discretionary

accruals indicators, affect the stock market value, including the accruals's impact to the dividend policy and working capital management?; (2) How much is the effects of dividend payout ability and policy, and how much is the impact of working capital policy on the performance level of company's market value?; (3) How does the business risk affect the debt's capital cost and the equity through Beta indicator? And also the accruals's impact on business risk through earning quality concept?

The Signal Theory or "The Signaling"

The basis of this theory is that managers and shareholders do not have the same access to information to company's information or the information asymmetry existence. There is certain information that is only known by the managers, while the shareholders do not know it. As a result, when the company's funding policy changes, it delivers information to the shareholders that make the company's value

changed, in other words, the sign appears or signaling (Desai, 2004, and Bhattacharya, *et al.* 2012)

The signal theory explains how the investors have the same information about company's prospects as its manager. It is called asymmetric information. But in reality, the managers have better information than the investors. It is called informative asymmetry, and it has a significant impact on optimal capital structure (Brealey *et al.*, 2008). In general case, market believed that a high result dividend gives signal that the company has a good financial performance. This situation is supported by effective communication between company's management and investors. It also assisted by the good reputation to avoid other problems (Fairchild, 2010).

Agency Theory and Asymmetry Information with the Dividend Policy

The results of Mollah's research, *et al.* (2000) showed that insider ownership gives significant negative effects to payment dividend. The higher agency cost that high growth company needs, the lower they pay the dividend. Desmukh's research (2005) found information asymmetry that is described as equity publication cost's reverse affect positively to dividend's payment. Informative asymmetry's effect on the dividend's policy is based on pecking order theory. While empirical study of Smith Jr. *et al.* (1992) showed evidence that informative asymmetry correlate negatively with dividend policy. As explained by Mao's model (2003), when the investment scale's increases with debt addition, it encourages the shareholders to substitute assets by reducing the dividend's payments on retained earnings. On the contrary, when the company faces over-investment condition due to excess free cash flow, in order to reduce these conditions, the retained earnings should be used to increase the dividend's payments. In order to reduce the agency conflict manager and shareholder when the free cash flow problem appears, can be conducted by increasing the dividend payment mechanism (to shift risk).

Dividend as Reduction of Agency Conflict

The research of Lilian *et al.*, (2012) showed a phenomenal result, by producing dividend payment to 31 countries, it shows low attractiveness on abnormal accruals and high-quality earning. The associative relation between dividend and earning quality is appear more in a country that has weak regulation and less informed environment. Furthermore, the analysis showed that the dividend payers not only have more accurate and better quality information but also a little biased expectations level. The dividends provides a good quality earning signals, especially in high asymmetric information countries.

The research of Gordon (1962) says that the constant dividend growth's level caused a constant expected return level, a high dividend payout tends to be follow by a high P/E indicators growth or low expected earnings growth. Brav *et al.* (2005) and Deshmukh (2005) have one word, showed out that managers are motivated to increase the unbalanced dividend result, if the earning prospect is estimated stronger in the future. The dividend's improvement is not encouraged by company's performance, but the signal is delivered on the value of future expectations. Miller and Modigliani (1958) related to irrelevance theory, assumed that the investment's return level which unable to meet the constant expected return growth have a high dividend payout that make a lower company's growth.

The Measurement Concept of Corporate Market Value Performance

Tucker and Zarowin (2006) used the earnings per share approach to measure the earning quality. The correlation is estimated between current and future earnings by using the interaction between earnings per share and income smoothing. If the income smoothing improved the earning information, the correlation between current and future earnings will be improved too (the earning quality will increase). The test's results showed that the interaction between

earnings per share and income smoothing has a statistically significant positive relation. It confirmed that income smoothing encouraged earning quality. The interaction between earnings per share and income smoothing is proven having a positive impact on stock return, it measures the abnormal return level of securities market as a response on unexpected component of corporate earning report (Scott, 2012).

Sloan (1996) developed Jones and Dechow model), it was developed to Kothari's (2005) model with "Performance Based Discretionary Accruals" by adding ROA variable. Total accruals are used as a foundation to determine performance capabilities; earnings consist of total accruals and cash flows. The analysis results showed a negative correlation between significant accruals and cash flows, because the accruals additive factors positively related to earnings performance.

Francis *et al.* (2004) measures the earning quality (earnings persistence) from the regression slope coefficient of current earning on logged earning; he also showed that accruals quality has significantly positive effects on cost of equity. The earning quality can effect the dividend growth significantly and positively. Hanlon (2005) showed that the company give persistency of current earnings and has an ability to predict future earnings. It also gives additional information for investors, particularly about the dividend yield or dividend growth.

The Implication of Working Capital on Company's Market Value

The research about the correlation between working capital and profitability was conducted Lazardis and Tryfondis (2006). It studied about working capital and profitability of companies at Greece's stock exchange by using cash conversion cycle variable for independent variable and gross operating profit for dependent variable. It resulted the negative correlation between cash conversion cycle and earning negative correlation between days of account receiveables and days of inventory of earnings. The faster the cash conversion cycle the more earning level improved.

Peel and Wilson (1996) emphasized to an efficient working capital management and practical implementation of credit management as the spearhead from company's health and performance level. Berry et al (2002) found that big company's developed profit because of the optimal working improvement of financial management. The study of De Chazal Du Mee (1998) confirmed that 60% companies experienced losses because of cash flow problems. Narasimhan and Murty (2001) emphasized that many industries need to improve return on capital employed (ROCE) by focusing on critical point such as freight costs, working capital's investment reduction; and working capital's efficiency improvement. Shin and Soenen (1998) and De Loof (2003) found the significant and strong correlation between working capital management and corporate's earning capabilities. The figure below explains about the working capital role:

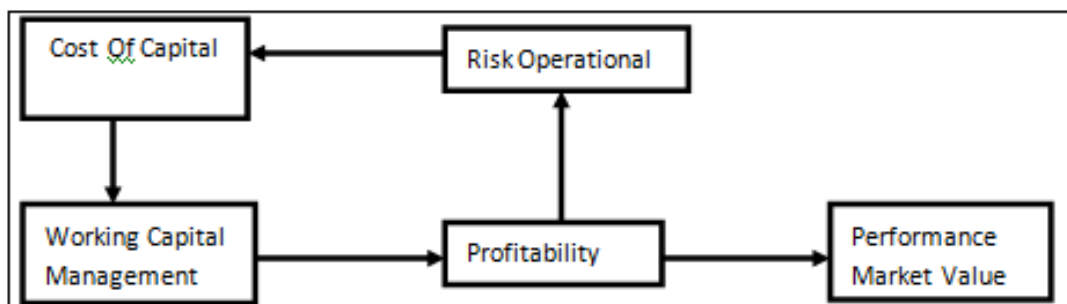

Note: Myers (1984) ; Gombola and Ketz (1983), Soenen (1993) and Lazaridis (2006).

Figure 2 Role of Working Capital Against Market Value Stocks

This research use working model management indicator on the accruals' effect, conducted by Barth et al (2001) it showed that there is a negative correlation between accruals and working capital management, which its components are divided into cash and supplies, including account recievable. Penman and Zhang (2002), use the modelling of working capital management's component as future prediction. The result is that the working capital component and also advertising cost and product development cost can not be used as prediction because of the accruals's item. Chan et al (2006) stated that theres is an effect of accruals on working capital (account recieveable, inventory and negative impact payable accounts). Kerstein and Rai (2007) developed Ali's research (1994 in Kerstein and Rai 2007), Ali investigated that there was a market response focusing on capital changing, compared with earning changing. Kerstein and Rai (2007) used earning management indicator with large unexpected working capital, there is a market reaction on discretionary accruals's and also the investors conduct predictions for the future cash flow to get earning quality rather than predictions for company's income fluctuation.

By comparing the capability of company's working capital in Indonesia, Fransisca et al (2014) found that management will conduct earning mangement aggressively in "not good" condition of company's working capital capability. This result study also measured the effect of company's leverage level with company's risk, when the risk increase, the earning management will be applied massively. It's also supported by

Fransisca et al, (2014), when the bankruptcy happen, from previous time earning management will be applied aggressively. The motive is to cover the evidence of debt agreements' violation. This verification is conducted by negative working capital indicators, so the company is unable to do the production operations.

Earning Management Studies

Earnings management has attracted the academists' attention by the end of 1960s. Breton and Taffler (1995) concluded that the accounting manipulation changed two basics of welfare transfer form. It is between managers, share holders, holders of shares or debt securities. Teoh et al (1998a,b) conducted research about earning management fluctuations in IPO event, the accruals usage occured aggressively in the process of open shares bidding. Burgstahler and Eames (1998) said that earning management and analysis forecast minimize the earning improment (earning surprises), it shows the income smoothing pattern because company's management doesn't want the sharp earning fluctuation occured as long as the management composition charging is not occured, Subramanyam (1996) concluded that market reaction tested the dicretionary accruals from pricing terms, studied the economical consequencey of accounting methods and the adverse implications of commitment and supervision systems.

Research Method

The study developed a framework of thinking through the image below:

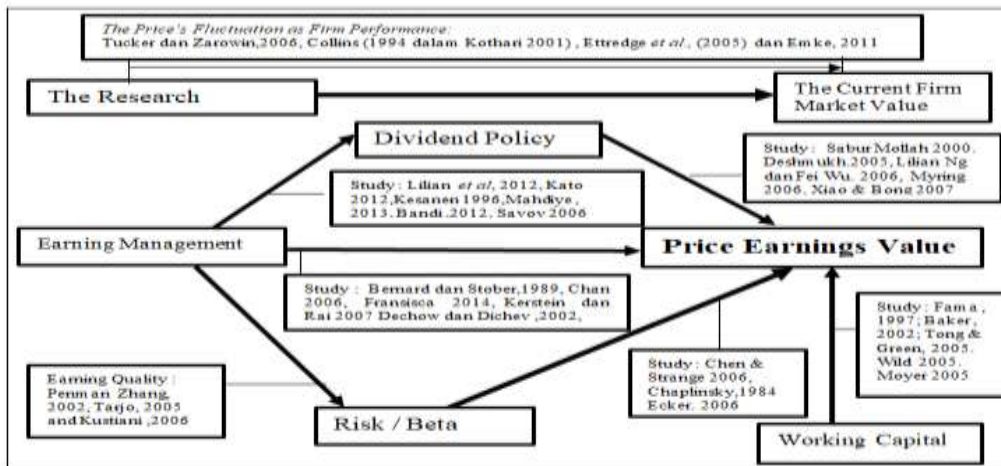

Figure 2. Model's Framework Research

RESEARCH METHODOLOGY

This research is explanatory causal model, using quantitative approach for mapping the investors's behaviour process on earning management. The research's objects are the listed companies in Jakarta Stock Exchange during 2001-2018. It is used secondary data by following the assumption

of path analysis' study that is conducted by Bollen (2009).

Research Variables

Based on explanation above, the variables' formulation is structured as follows:

Table 1. The Eplanation of Indicator Variables

Variabel	Dimension Indicator	Reference
<i>Earning Management</i>	$Total\ Accruals\ (TAC) = NI_{j,t} - CFO_{j,t}$ $TAC_t = \beta_0 + \beta_1 A/R_{j,t} + \beta_2 A/P_{j,t} + \beta_3$ $INV_{j,t} + \beta_4 Profit\ Margin_{j,t} + \epsilon_{j,t}$	Dopuch et al, (2012), Yoon et al, (2012) Zarowin (2012)
<i>Cost Of Debt</i>	Ratio Cost Of Debt = (Cost Of Debt)/ Net Revenue	Chen et al (2006), Binsbergen (2010),
<i>Dividend</i>	Dividend Pay Out = Dividen / Earning Dividend Pay Out d (t and t+1)	Tong (2005), Deshmukh (2005), Xiao & Bong (2007)
<i>Working Capital</i>	Net WC=Current Asset-Current Liabilitiesr Ratio WC= WC/Current Asset	Barth, (2001), Chan, (2006) Dechow&Dichev (2002) ,Sloan (1996).
<i>Performance Market Value</i>	Ratio PBV=Price/Book Value Ratio PER=Price/Earnings	Tucker et al (2006), Emke, (2011), Dechow et al (2002) , Eldomiatty (2005), Chen et al (2006),
<i>Resiko</i>	Beta (Varians ROA) Standard Deviation (period 5 tahun)	Chaplinsky,(1984), Ecker,(2006) Penman et al (2002), Dechow et al (2002),
<i>Cost Of Equity</i>	Model Ohlson 1995 $r = (Bt + Xt+1 -Pt) / Pt$ dimana $E_{(t+1)} = X_{t+1} + \delta$	Ohlson (1995), Botosan (2007) Francis, (2004). Supanvanij. (2006), Myring (2006),

The Measurement Indicators of Earning Management: Discretionary Accruals

In this research, the earning management measurement model is a model developed by Dopuch et al, (2012) and Yoon et al. (2012) through Discretionary Accruals (DAC) indicator. It is the difference total results between Total Accruals (TAC) with Non Discretionary Accruals (NDAC). For obtaining the Discretionary Accruals, the calculation is carried out through Non Discretionary Accruals (NDAC) as a prediction value or fitted value. The Dopuch Model is assumed to anticipate the weakness of Kothari Model in reducing the error value (Zarowin, 2015).

The Modelling Path Analysis I: Earning Management and PBV

The previous studies assumed that accruals encourages the management to apply

high yielding dividend pay out policy that can affect the stock price fluctuations (Kato; 2002, Lilian et al, 2012, Kesanen; 1996 Mahdiye; 2013, Bandi, 2012). The working capital has a role in affecting market value, including investor’s perception that is sensitive on working capital movement significantly (Kerstein and Rai 2007). This research studies on the financial ratio’s correlation between stock value’s measurements by using PBV indicators which put the variable of discretionary accruals. This model is a beginning test’s result in testing process of earning management with market value. Research of Balakrishnan (2016) assumed that company’s risk level with conservatism indicator affect significantly positive on company’s value. The figure below explain the encouraged relation between Discretionary Accruals and PBV indicator.

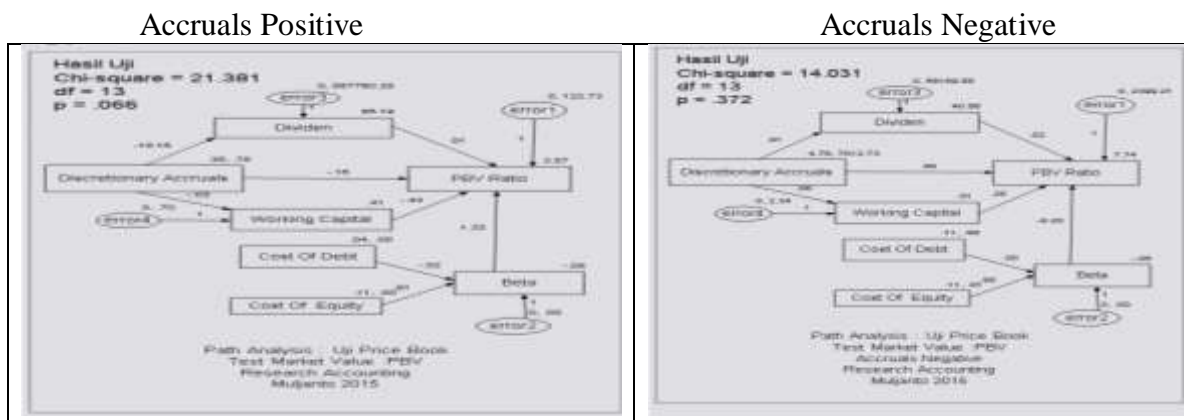

Figure 3 Relationship Model Market Value Performance by PBV

Model path analysis equation can be written as follows:

$$PBV = \beta_1 Dividen + \beta_2 Working Capital + \beta_3 Discretionary Accruals + \beta_4 Resiko + Z1 (Error) \quad (1)$$

$$Beta = \beta_5 Cost Of Equity + \beta_6 Cost Of Debt + Z2 (Error) \quad (2)$$

$$Working Capital = \beta_7 Cost Of Debt + \beta_8 Discretionary Accruals + Z4 (Error) \quad (3)$$

$$Dividen = \beta_9 Discretionary Accruals + Z3 (Error) \quad (4)$$

The Path analysis result of the above picture showed that there is a compliance of determined criteria. In other words, this result’s research showed there’s variables correlation that has been arranged, has significant correlation. The difference of

result can be seen when control variable's test have a difference level, like below:

Table 3 Criteria Path Analysis for PBV

Criteria	The Critical Value	Interpreting
Chi-Square	Diharapkan kecil	Fit
Probability	$\geq 0,05$	Fit
RMSEA	$\leq 0,08$	Fit
CMIN/DF	$\leq 2,00$	Fit
TLI	$\geq 0,95$	Fit
CFI	$\geq 0,95$	Fit
Degree of Freedom (DF)	Positive (+)	Fit

The results of Kasanen's research (1996), is the first research on dividend payment with earning management. Some non-financial companies in Finland were institutional shareholders that wanted huge dividend and didn't want to have a fluctuation in dividend payment, in other words it happened the process of dividend smoothing. During 1970-1989, the company's earning level is depended absolutely on the target of dividend payout payment. The result of Kato's research showed the earning management implementation on Japanese banking company with dividend payment (Kato, 2012). It became evidences of dividend payment with motivated earning management. It also encouraged the result of Mahdiye et al (2013), stated that there is a relationship between dividend and discretionary accruals in the Teheran Stock Exchange. Savov (2006) found a company's motive to apply the dividend payout policy, it used accruals aggressively. By testing on many Germany companies in industrial sector, there is a negative correlation between dividend payout policy on investment and earning management policy.

The results showed that companies used positive accruals. It showed that dividend policy is not based on earning management, but when the companies used negative accruals, then, there is a correlation between earning management and dividend policy. It can be controlled by working capital that can make the same results. It concluded that the earning management can be seen by dividend and working capital policy.

The Modelling of Path Analysis II: Earnings Management and PER

This study uses discretionary accruals that directly tested with stock exchange value with modelling PER pattern. P/E ratios showed a higher level of strong growth prospect when all ratios are in the lowest level from a high risk company. When the company has a below average P/E ratio, it recommends that the company has a high risk having low growth expectation. (Brealey *et al*, 2008). By using the same modeling with the previous analysis path model (with PBV indicator), the charts below are made to see the interaction relationship with PER.

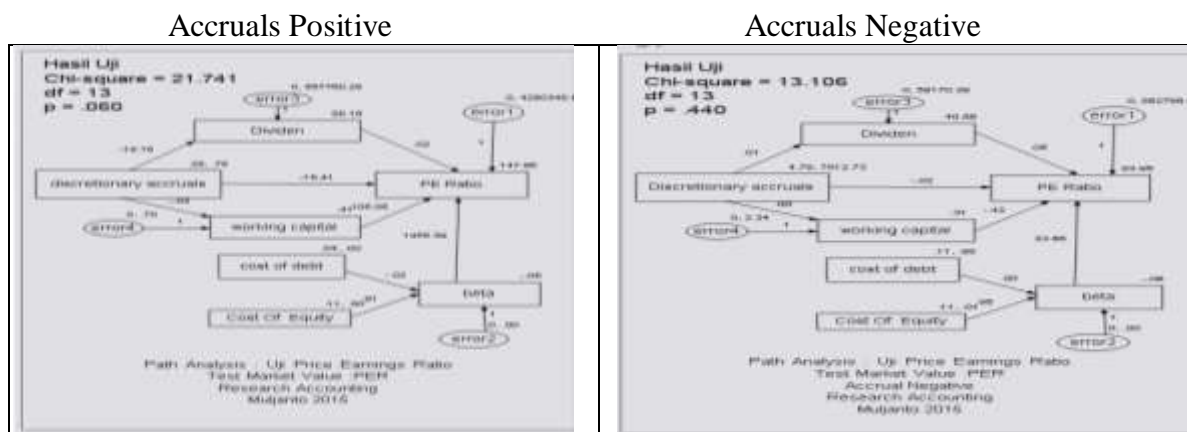

Figure 4 Relationship Model Market Value Performance by PER

The model is written as the following equation:

$$PER = \beta_1 Dividen + \beta_2 Working Capital + \beta_3 Resiko + \beta_4 Discretionary Accruals + Z1 (Error) \quad (5)$$

$$Beta = \beta_5 Cost Of Debt + \beta_6 Cost Of Equity + Z2 (Error) \quad (6)$$

$$Working Capital = \beta_7 Cost Of Debt + \beta_8 Discretionary Accruals + Z4 (Error) \quad (7)$$

$$Dividen = \beta_9 Discretionary Accruals + Z3 (Error) \quad (8)$$

By doing the Discretionary Accruals against PER, so the results of relation as shown below:

Xie (2001) studied about stock market efficiency; she found that market argumentation is not efficient as if there is over value by using accruals. Company's management send messages through earning management, so that the effect of dividend and working capital is very significant. The dividend policy is as conflict of interest

reduction while working capital is as company's operational cash flow performance in finding the operational activities.

Earnings management affect the capital cost positively. The higher the accruals level, the capital cost is high too. Earning management affect the capital cost significantly. The objective of earning management is to repair the measurement of both risk. According to Wiwik (2005), the manipulation of accounting transaction is conducted based on management desires that influence investor's perception on company risks. These risks are divided into two component. They are: (1) Risks related to of yield that is counted by the price of per share (price per earning); (2) Risks related to the structure finance that is counted with debt equity ratio.

By conducting the study using PER, the test path above can be assumed meeting the minimal predetermine limit. In other words, the correlation between variables is consistent and permanent.

Tabel 5 Criteria Path Analysis for (PER)

Criteria	The Critical Value	Interpreting
Chi-Square	More Less	Fit
Probability	≥0,05	Fit
RMSEA	≤0,08	Fit
CMIN/DF	≤2,00	Fit
TLI	≥0,95	Fit
CFI	≥0,95	Fit
Degree of Fredom (DF)	Positive (+)	Fit

Based on the research above, it can be concluded that earning management positively influence the company's performance through ratio PER. The higher the earning management performed by the company in manipulating its earning, the higher its capital cost because the level of information risk will be higher as well. The consequences is that the investors will raise the capital cost rate. The company maximize its earning in order to increase its stock price. It will make the dividend, that will be returned to investor, higher too. The management has incentive or even disincentive to disclose informations extensively, including the reduction of capital cost.

In general, the research results indicates that a company that use negative accruals gives some different indicator with a company that use positive accruals. The usage of positive accruals demonstrated the application of conservative level to reduce the risk level, related with earning quality concepts. In this test, by using the level of variable control measurement and market value, it can be proved obviously that there is a different on dividend policy and working capital on market value. The earning management's application affect the financial report. The results of path

analysis proved that working capital is a sensitive indicator in company's earning report and dividend policy. By doing this, we can see the company's capability in sending signals.

First : Game Theory in the Investor Perception

This research related the company's performance modelling and investor's perception model, with the based principle agent model, it describes the effect that is made by informative assymetry. While the management gives the pattern of company's earning management without considering the double identifications. Because the company's management might have have some share in practical cases (Jensen and Meckling, 1976). From the picture below can be seen that there is a type of trade off and correlation between behavior orientation and outcome orientation (remuneration, bonus, equity owner and ither sources that is related to share holders wealth). This empirical reearch used the game theory to analyze the decision masking and startegies of each side, so that it is implication of agency theory in publishing the financial report. This interaction is related with uncertainty and asymmetric information between investor and management.

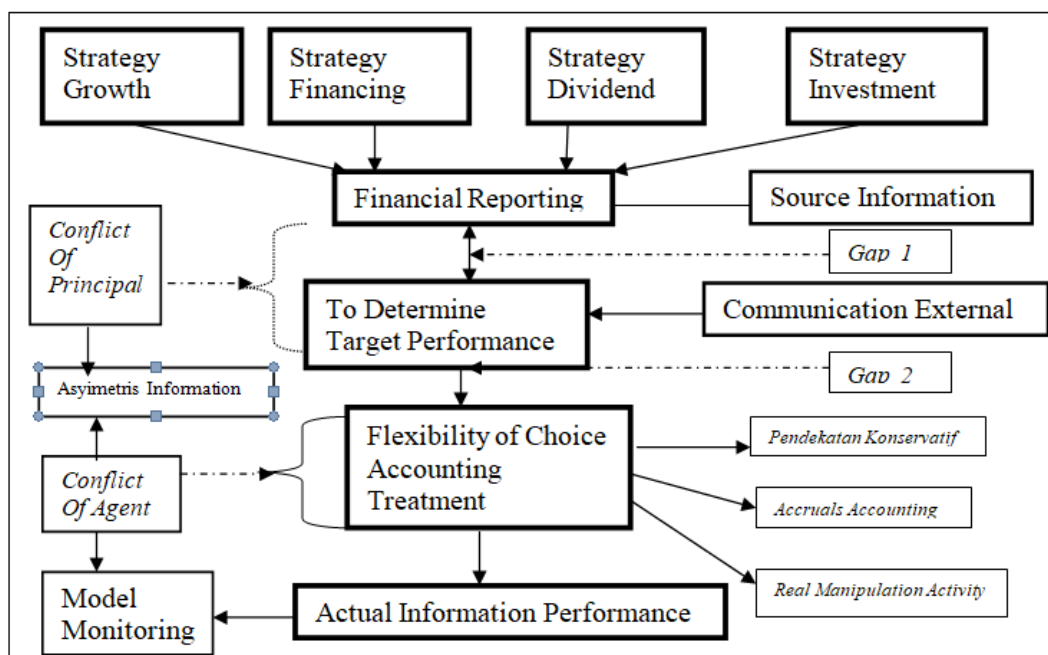

Source: Compilation Coate (1999) and Bhattacharya et al (2012)

Figure 6 The Impact of Asymetris Information on Game Theory

In

game theory, beside the uncertainty that appear from the real natural condition, there is an analysis of decision making and strategies conducted by each player in a conflict. This game theory is a supplementary explanation towards the theory of decision and investment (Cushing, 1999), This showed out that a freedom from each side has proclivity to change the rule in business strategic game. So that the moral management choice affect the decision of conservative accounting and accruals usage, so the investors then have investment choice considering conservative concept and earning management towards performance achievement target, especially the level investment target.

Investors want a relevant and reliable information of financial report that help in assessing the value and risk of the investment. The manager does not always want to reveal the information needed by investors, prefer not to reveal all the accounting policy used so that he can have space to manage the earning by changing the policy. There is a conflict between management and principal, with different interest and effort to maximize the expected utility between them, that cause asymmetric info. This maximize expected utility is also explained by the game theory well. This empirical testing has proven the publication financial reporting is an practical implication of game theory, because of the investor capability in detecting the accruals's using. In this case, this mentioned investor is shareholders in dominant position or strategic partners, who have potential power in making out the critical influences on management's decision.

First Conclusion

By arranging the path analysis chart, it obviously showed that the accruals usage has a strong correlation with company's market value performance. By using the variable control, it's seen that the company use positive accruals is able to increase the market value, but in negative accruals usage the negative contribution occurs. Generally, the

company's behavior toward earning management is same, the differences happens in dividend policy and working capital on company's market value.

Second Conclusion

The effect of accruals usage can influence the dividend policy and working capital. By using the variable control, it can be seen that the company uses positive accruals have negative correlation between its dividend and accruals. But, by considering the company used negative accruals, the dividend and accruals occurs positively. Based on the correlation between working capital and accruals, the positive accruals has negative relation and on the negative accruals usage, the second relation is positive.

Third Conclusion

By considering the risk element, it can be assumed that the risk has a positive relationship with company's value performance through positive usage. But by using negative accruals, the risk has negative relation with market value performance. It reflects that the management is trying to minimize the risk through accruals's usage, while the company with conservative level has a high market value toward the high company's risk. It is assumed as compensation for investors to the investment. Shortly, the conservative relation occur because of asymmetric information, so that the stock price fluctuation can be anticipated by investor through financial report benefit.

Research's Limitation

The research has a limitation problem, the effect of asymmetric information and conservative is not included as an integrated model. It is that the research objectives are limited to the investor's anticipation toward the benefit of financial report through investment decision. Other thing is a limitation of financial report in making variable indicator in asymmetric information and conservative. For the next

research, the conservative and asymmetric information will be included relating to an earning management with company's value performance.

REFERENCE

- Balakrishnan, A (2016), Size, Value, and Momentum Effects in Stock Returns : Evidence from India”, *Vision* 20(1) 1–8 © 2016 MDI SAGE Publications
- Baker H. Kent and Gary E. Powell, (2015), Dividend Policy In Indonesia: Survey Evidence From Executives, *Journal of Asia Business Studies*, Vol. 6 Iss 1 pp. 79 – 92.
- Ball, Ray and Philip Brown. (1968). An Empirical Evaluation of Accounting Income Number *Journal of Accounting Research*. Vol 6
- Bandi. (2013), Finance Perspective versus Accounting Perspective: The Case of Earnings Persistence in Indonesia *International Journal of Economics and Finance*; Vol. 4, No. 9; 2012, Published by Canadian Center of Science and Education.
- Barth, M.E., Cram, D.P. and Nelson, K.K. (2001), “Accruals And The Prediction Of Future Cash Flows”, *The Accounting Review*, Vol. 76 No. 1, pp. 27-58.
- Bhattacharya Nilabhra, Hemang Desai and Kumar Venkataraman, (2012), Does Earnings Quality Affect Information Asymmetry? Evidence from Trading Costs”, *Contemporary Accounting Research*, Volume 30, Issue 2, pages 482–516, Summer 2012 (June)
- Binsbergen Jules.H., Van, John Graham, Jie Yang, (2010), The Cost Of Debt, *The National Bureau of Economic Research*, Working Paper no 16023
- Bollen, K. A. 1989. *Structural Equation Models with Latent Variables*. New York: John Wiley and Sons, Ltd.
- Botosan, A Christine. (1997). Disclosure Level And The Cost Of Equity Capital”. *The Accounting Review*, 72: 323-349.
- Brav, A., Graham, J., Harvey, C. & R. Michaely. (2005). Payout Policy In The 21st Century. *Journal of Financial Economics*, 77, pages 483-527.
- Brealey, Myres, Allen, (2008) "*Principles of Corporate of Finance*", 9th, Mc Graw Hill.
- Breton, G. and Taffler, R.J., (1995), “Creative Accounting And Investment Analyst Response” *Accounting and Business Research*, 25, 81-92.
- Brugstahler, D dan Earnes, M, (2006), Management Of Earnings And Analyst To Achieve Zero and Small Positive Earnings Surprises, *Journal Of Business Finance and Accounting*, Vol 33 (5-6), pp 633-656
- Chan, K; L.K.C. Chan; N. Jekadeesh; and J. Lakonishok. (2006). Earnings Quality and Stock Returns, *University of Illinois at Urbana-Champaign*, Working Paper Series,
- Chaplinsky, Susan (1984). The Economic Determinants of Leverage: Theory & Evidence. *Unpublished Ph.D dissertation*, University of Chicago,
- Coate, Charles J. (1999), Discussion Of Economic Analysis Of Accountants Ethical Standards: The Case Of Audit Opinion Shopping, *Journal of Accounting and Public Policy* 18 (1999) 365±373
- Cohen, Daniel A. dan Paul Zarowin. (2010). Accruals-Based and Real Earnings Management Activities Around Seasoned Equity Offerings. *Journal of Accounting & Economics* Vol. 50 No. 1: 2-19
- Daniel. Kent, and Sheridan Titman.(1999), Market Efficiency in an Irrational World, *Financial Analysis Journal*, 55. 1999. pp. 28-40.
- De Chazal Du Mee. (1998). Research Study on Small and Medium Enterprises, *Final Report*.
- Dechow, P.M and I.D. Dichev. (2002). The Quality of Accruals and Earnings: The Role of Accruals Estimation Errors, *The Accounting Review*, Vol. 77, .
- Dechow, P.M, (1994), Accounting Earnings and Cash Flows as Measures of Firm Performance: The Role of Accounting

- Accruals, *Journal of Accounting and Economics*, 18, 3-42.
- Dechow, P.M.; R.G. Sloan; and A.P. Sweeney. (1995). Detecting Earnings Management, *The Accounting Review*, Vol. 70, April: 193 - 225.
- Desai, H; S. Rajgopal; dan M. Venkatachalam. (2004), "Value-Glamour and Accruals Mispricing: One Anomaly or Two" *The Accounting Review*, Vol.79, April, 355 – 38.
- Deshmukh, Sanjay, (2005), The Effect of Asymmetric Information on Dividend Policy, Available from: URL: <http://www.Proquest.com>
- Dopuch, N., Mashruwala, R., Seethamraju, C., & Zach, T. (2012). The Impact Of A Heterogeneous Accrual - Generating Process On Empirical Accrual Models. *Journal of Accounting, Auditing, and Finance*, 27, 386–411.
- Ecker, F.; J. Francis; I. Kim; P.M. Olsson; and K. Schipper. (2006), A Return-Based Representation of Earnings Quality, *The Accounting Review*, Vol. 81, No. 4, July.
- Emke Nwaaze, (2011), Are Incentives For Earnings Management Reflect In The ERC : Large Sample Evidence, *Advance in Accounting Incorporating Advances in International Accounting*, 27 (2011) al 26-38.
- Francis, J.; R. La Fond; P.M. Olsson; and K. Schipper. (2004). Costs of Equity and Earnings Attributes, *The Accounting Review*, Vol. 79, No. 4, Oktober: 967 - 1010.
- Fransisca Fortunata Gunawan, Felizia Arni Rudiawarni, Aurelia, CC Sutanto, (2014), Hubungan Antara Financial Distress Dengan Earnings Management Pada Badan usaha Sektor Manufaktur Yang Terdaftar Pada BEI Periode 2010-2012, *Jurnal Ilmiah Mahasiswa Universitas Surabaya* vol 3 no 1.
- Gombola M J and Ketz J E,(1983), Financial Ratio Patterns in Retail and Manufacturing Organizations, *Financial Management*, Vol. 12, No. 2, pp. 45-56.
- Gordon, Myron J. (1963). "The Investment Valuation And Financing Of The Corporation". Homewood. IL. *Journal Of Finance*, May 1963.
- Hanlon, M. (2005). The Persistence and Pricing of Earnings, Accruals, and Cash Flows When firms Have Large Book-Tax Differences, *The Accounting Review*, Vol. 80, No. 1, January: 137 - 166."
- Hair, Black, Babin. Anderson.Tatham, (2008), "Multivariate Analysis", Sixth Edition, McGraw Hill New Jersey
- Healy,P.M and Palepu, K.G., (1990), Effectiveness Of Accounting-Based Dividend Covenants, *Journal of Accounting and Economics*, 12, 97-123.
- Jeong-Bon Kim, Byung Cherl and Charlie Sohn, (2013), Real Earnings Management And Cost Of Capital. *Journal. Accounting Public Policy* 32 (2013) 518–543
- Jensen, Michael, and William Meckling, (1976), Theory Of The Firm: Managerial Behavior, Agency Costs, And Ownership Structure, *Journal of Financial Economics* 4, 305-360.
- Kato Hideaki Kiyoshi, Uri Loewenstein, Wenyuh Tsay,(2002), Dividend policy, cash flow, and investment in Japan, *Pacific-Basin Finance Journal* 10 (2002) 443 – 473
- Kasanen, E., J. Kinnunen, J. Niskanen, (1996), Dividend-based earnings management: Empirical evidence from Finland, *Journal of Accounting and Economics*, 22.
- Kerstein, Joseph and Rai, Atul., (2007), Working Capital Accruals And Earnings Management, *Investment Management & Financial Innovations*, Volume 4, Issue 2,
- Kothari, S.P, Andrew J Leonne, Charles E Wesley, (2005), Performance Matched Accruals Measures, *website : MIT.Org*.
- Lakonishok, J. and T. Vermaelen,(1986), Tax-Induced Trading Around Ex- Dividend, *Journal of Finance*, page 38, 107-126.
- Lazaridis I, Tryfonidis D, (2006). Relationship Between Working Capital Management and Profitability of Listed Companies in the Athens Stock

- Exchange. *Journal of Financial Management and Analysis*, 19:16-25.
- Leuz, C., Nanda, D., & Wysocki, P. (2003). *Earnings Management And Investor Protection : An International Comparison*. *Journal of Financial Economics*. 69. March 2003.
- Lilian Ng, Wen He, Nataliya Zaiats, and Bohui Zhang, (2012) , Do Dividends Signal Earnings Manipulation? Retrieved from URL: <http://www.Proquest.com>
- Mahdiye Ebrahimpour, Heydar Mohammad Zadeh Salteh, Rasoul Baradarane Hasan Zadeh, (2013), The Study Of The Effect Of Dividend Earnings On The Quality Of Earnings With Emphasis On The Industry Type, *European Online Journal of Natural and Social Sciences* vol.2, No. 3(s), pp. 1034-1042
- Michaely, R. and Murgia, M. (1995), The Effect of Tax Heterogeneity on Prices and Volume Around the Ex-Dividend Day : Evidence from the Milan Stock Exchange, *Review of Financial Studies* vol 8, 369-399.
- Modigliani, F. and Miller, M.H., (1958). The Cost Of Capital, Corporation Finance And The Theory Of Investment, *American Economic Review*, 48, 261-297.
- Mollah, A. Sabur., Kevin Keasey, Helen Short, (2000), The Influence of Agency Costs on Dividend Policy in an Emerging Market: Evidence from the Dhaka Stock Exchange. *The Sixth ENBS Workshop University of Oslo*, Norway, May 14-16,
- Myring, Mark (2006), The Relationship Between Returns And Unexpected Earnings: A Global Analysis By Accounting Regimes, *Journal of International Accounting, Auditing and Taxation*, 15 (2006) 92–108
- Ohlson, J.A. (2006). A Practical Model of Earnings Measurement, *The Accounting Review*, Vol. 81, No. 1, January: 271 - 279.
- Priantinah, Denies. (2009). Korelasi Sistem Informasi Akuntansi Dengan Sistem Kinerja Manajemen, An Empirical Research in Universitas Negeri Yogyakarta, 2009.
- Prima Santy, Tawakkal, Grace T. Pontoh ,(2012),Pengaruh Adopsi IFRS Terhadap Manajemen Laba Pada Perusahaan Perbankan Di Bursa Efek Indonesia, *Penelitian Unhas*, Makasar 2012.
- Penman, S.H and X.J. Zhang. (2002). Accounting Conservatism, the Quality of Earnings,and Stock Return, *The Accounting Review* , Vol. 77, No. 2.
- Roychowdhury, Sugata. (2006). “Earnings Management Through Real Activities Manipulation”. *Journal of Accounting and Economics* “, Vol. 42 No. 3: 335-370.
- Savov; Sava, (2006), Earnings Management, Investment, and Dividend Payments, *SSRN Electronic Journal*, · July 2006,
- Scott, W.R., (2015), “*Financial Accounting Theory*”, Prentice Hall, Scarborough
- Soenen L A,(1993), Cash Conversion Cycle and Corporate Profitability, *Journal of Cash Management*, Vol. 13, No. 4, pp. 53-58
- Subramanyam, K. R., (1996), “The Pricing Of Discretionary Accruals”, *Journal of Accounting and Economics*, 22, 249-281.
- Sweeney, A.P., (1994), Debt Covenant Violation And Managers Accounting Response, *Journal of Accounting and Economics*, 17, 281-308.
- Sylvia Veronica N.P. Siregar, and Siddharta Utama, CFA, (2005), Pengaruh Struktur Kepemilikan, Ukuran Perusahaan, Dan Praktek Corporate Governance Terhadap Pengelolaan Laba (Earnings Management), *SNA VIII Solo*, 15 – 16 September 2005, hal 475.
- Teoh, S., Welch, I., and Wong, T., (1998a), Earnings Management And The Long Run Market Performance Of Initial Public Offerings, *The Journal of Financial*, 6, 1953-1974.
- Titman, Sheridan and Roberto Wessels, (1988). The Determinants of Capital

- Structure Choice. *Journal of Finance*, Vol.XLIII, No.1, pp.1-19.
- Tong, Guanqun., and Christopher J.Green, (2005), Pecking Order or Trade-off Hypothesis: Evidence On The Capital Structure Of Chinese Companies. *Applied Economics*, 37, pp.2179-2189.),
- Tucker, J.W. and P.A. Zarowin, (2006). Does Income Smoothing Improve Earnings Informativeness?, *The Accounting Review*, Vol. 81, No. 1,January: 251 - 270.
- Watts,R. and Zimmerman,J.L.,(1986), "*Positive Accounting Theory*", New Jersey:Prentice-Hall, Inc."
- Wiwik Utami. (2005). Pengaruh Manajemen Laba terhadap Biaya Modal Ekuitas (Studi pada Perusahaan Publik Sektor Manufaktur). *SNA VII*. Solo
- Xie, H, (2001). The Mispricing of Abnormal Accruals. *The Accounting Review*, 76(3): 357-373.
- Yoon, Soon Suk., Kim, Hyo Jin., dan Woodruff, Gregg, (2012), "On The Models And Estimation Of Discretionary Accruals ", *IFAS. University Xiamen*.
- Zarowin, Paul (2015)," Estimation of Discretionary Accruals and the Detection of Earnings Management" , *Oxford Handbooks Online*, Publication Date: May 2015.